

Stand Mobile "Crêpes & Co"

"Crêpes & Co" Waffle House

Verkaufsstand "Crêpes & Co" (Holz) mit Zubehör (40 Teile)
La Creperie Móvil "Crêpes & Co" • Stand Mobile "Crêpes & Co"

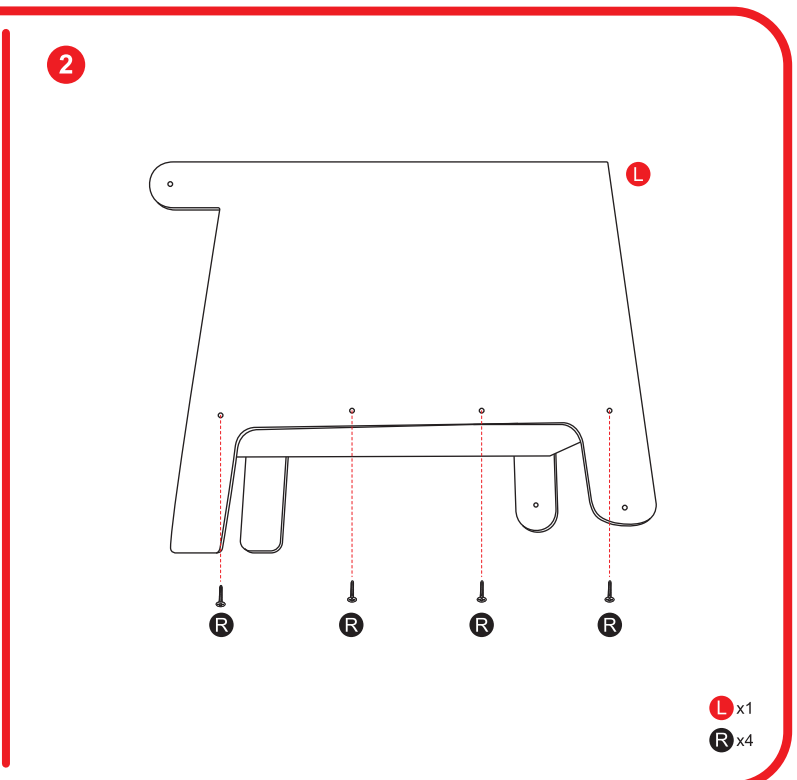
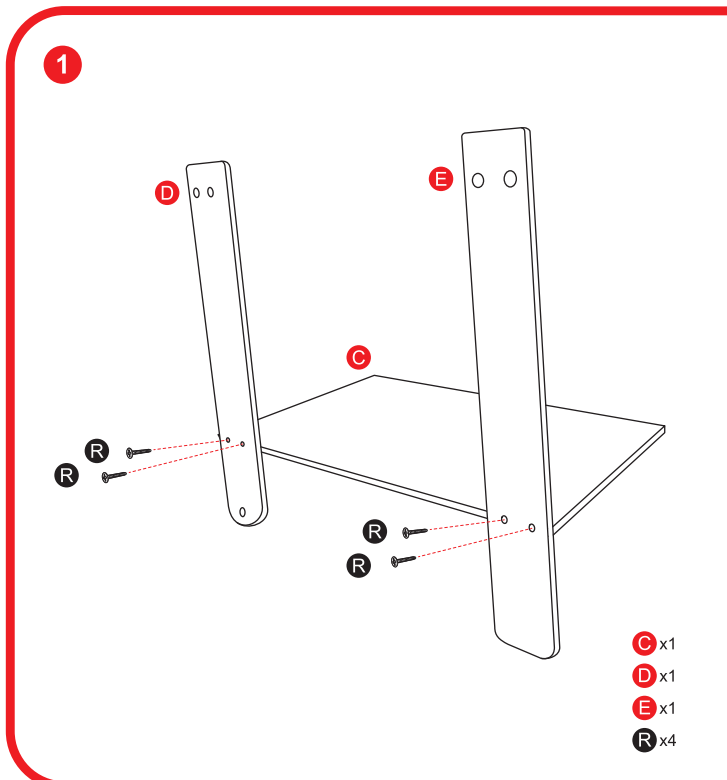
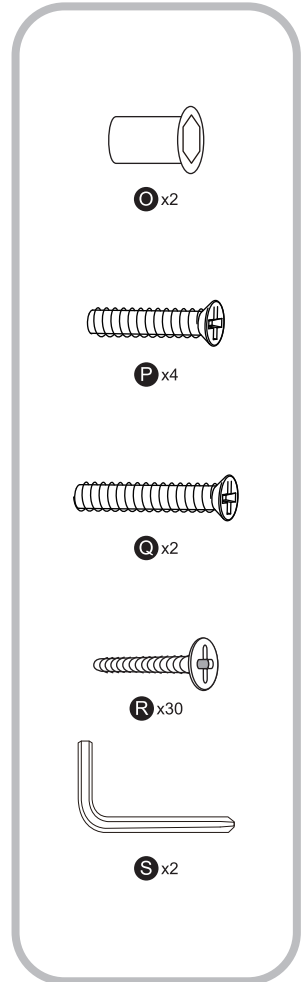
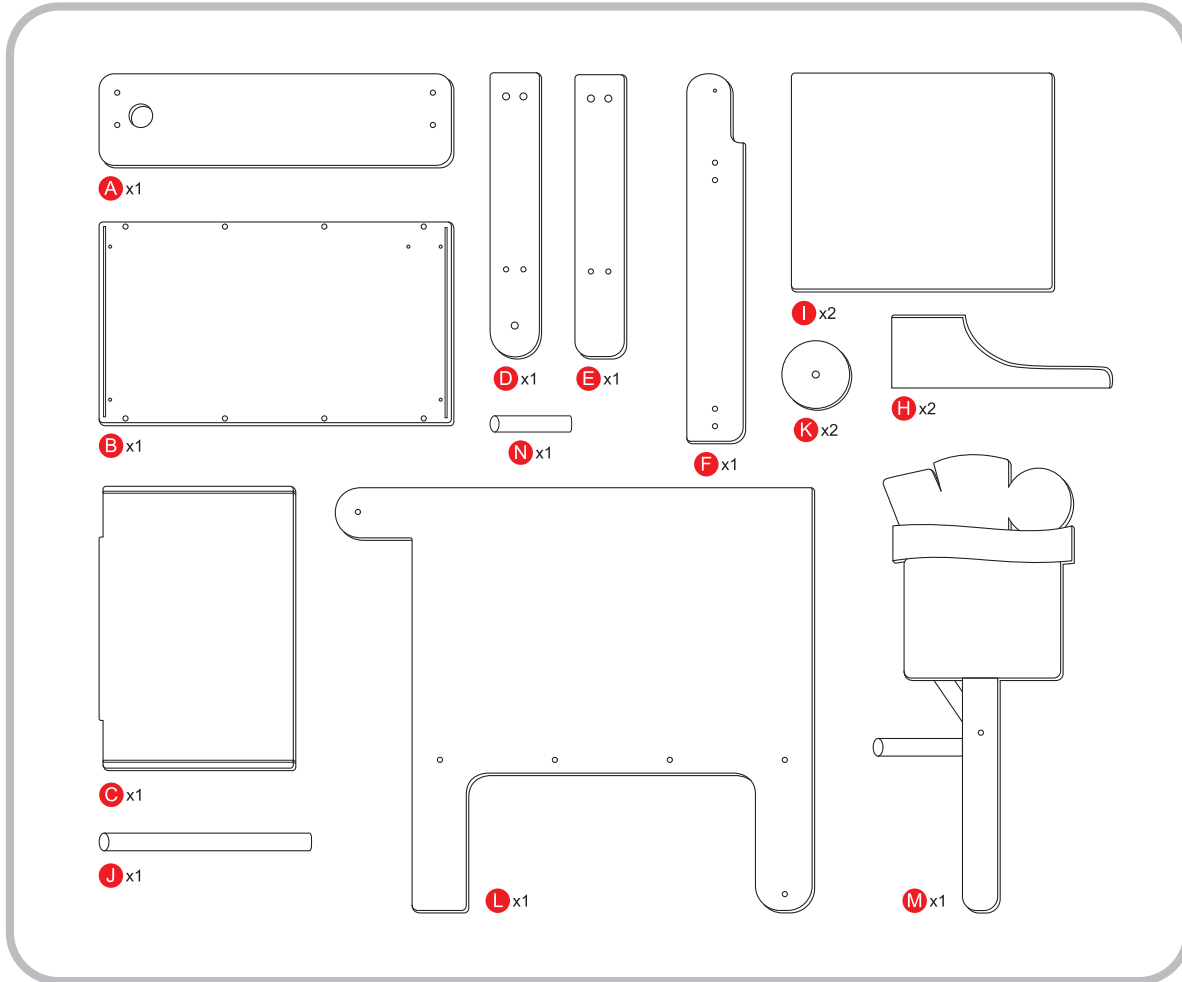

3

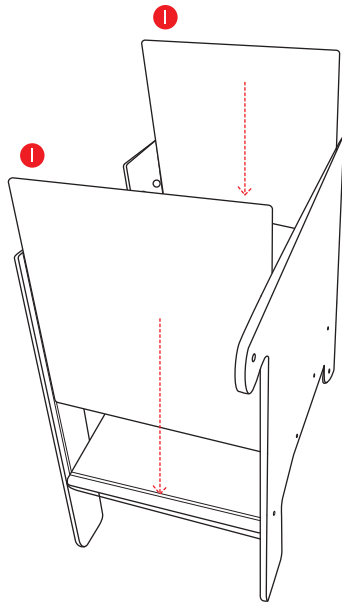

I x2

4

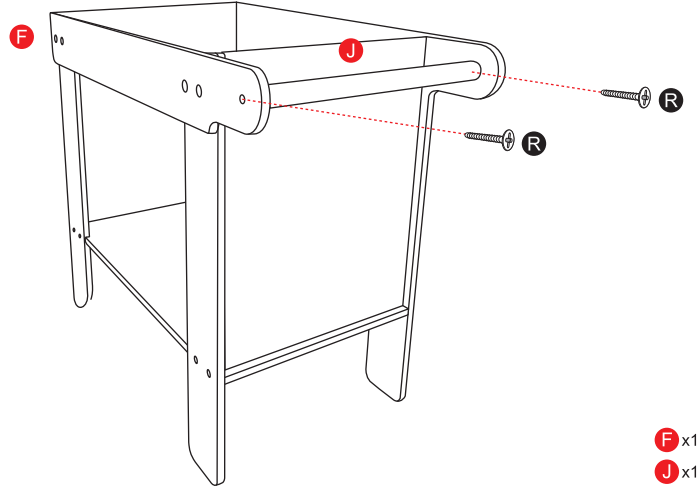

F x1

J x1

R x2

5

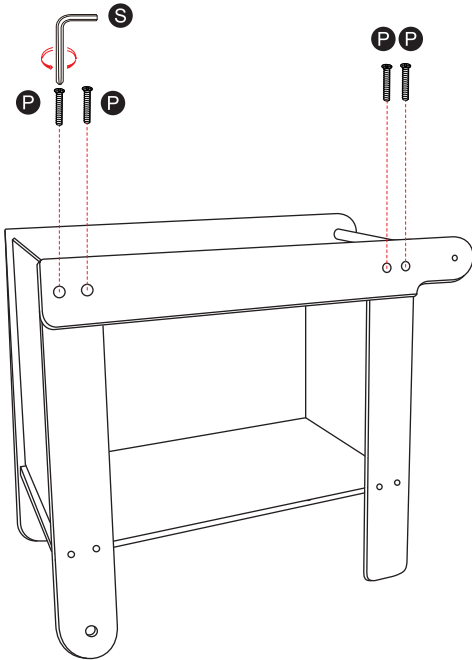

S x1

P x4

6

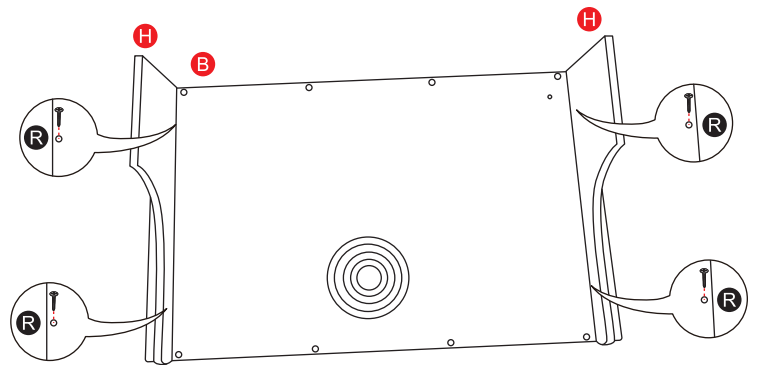

B x1

H x2

R x4

7

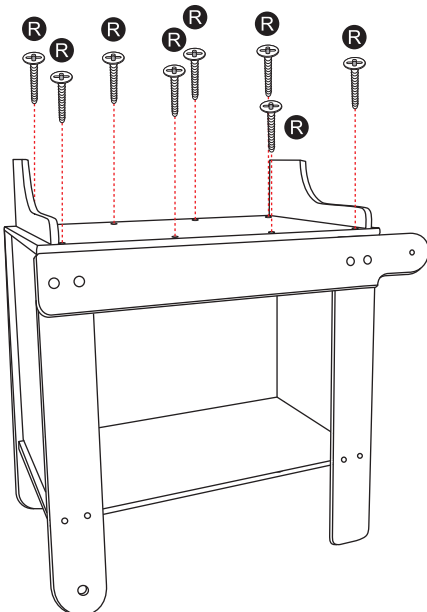

R x8

8

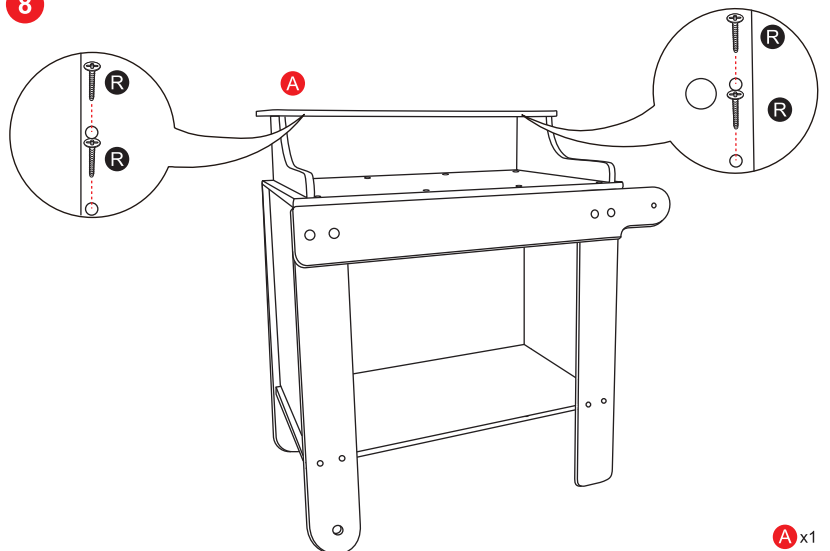

A x1

R x4

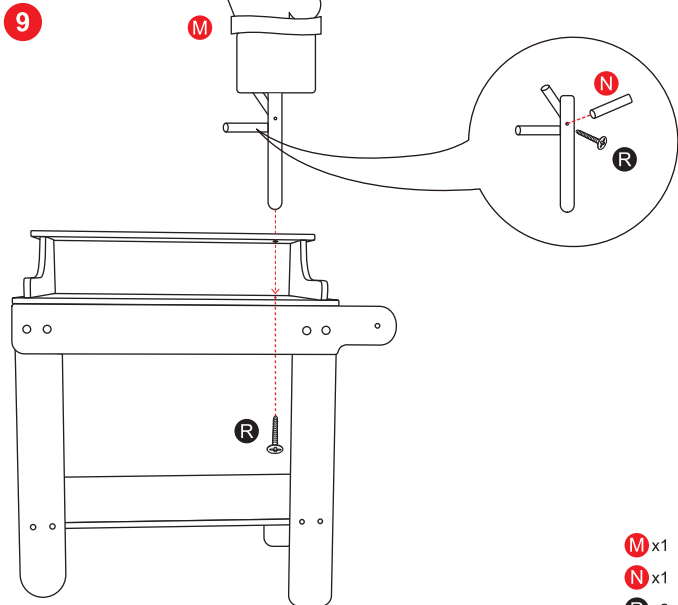

M x1
N x1
R x2

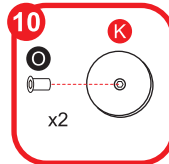

11

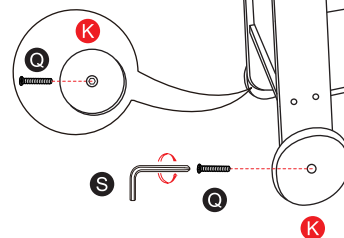

K x2
Q x2
S x1

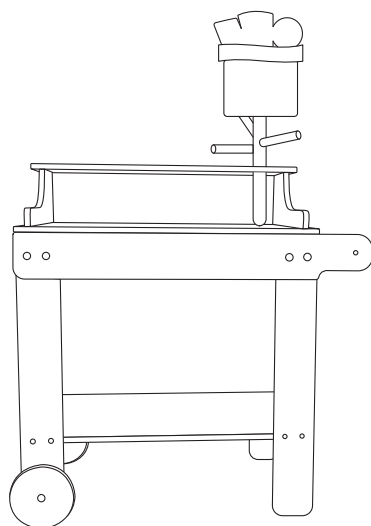

F ⚠ **ATTENTION !** Ne convient pas aux enfants de moins de 3 ans. Petites pièces. Danger d'étouffement. Laver soigneusement les accessoires avant utilisation. Montage de l'article à effectuer par un adulte. Retirer tous les emballages avant de donner le jouet à votre enfant. Informations à conserver. Laver soigneusement les accessoires avant utilisation.

ENG ⚠ **WARNING!** Not suitable for children under 3 years. Small parts. Choking hazard. Please wash the accessories thoroughly before use. Item is to be assembled by an adult. Remove all packaging materials before giving the toy to your child. Please retain for information. Please wash the accessories thoroughly before use.

D ⚠ **ACHTUNG!** Nicht für Kinder unter 3 Jahren geeignet. Kleinteile. Ersticken-gefahr. Das Zubehör vor dem Gebrauch bitte gründlich abwaschen. Das Produkt muss von einem Erwachsenen zusammengebaut werden. Entfernen Sie das gesamte Verpackungsmaterial, bevor Sie das Spielzeug Ihrem Kind geben. Bitte Anschrift für Rückfragen aufbewahren. Das Zubehör vor dem Gebrauch bitte gründlich abwaschen.

NL ⚠ **WAARSCHUWING!** Niet geschikt voor kinderen onder 3 jaar. Kleine onderdelen. Verstikkingsgevaar. Was de accessoires grondig voor gebruik. Montage van het voorwerp dient door een volwassene te gebeuren. Verwijder alle verpakking alvorens het speelgoed aan uw kind te geven. Informatie te bewaren. Was de accessoires grondig voor gebruik.

E ⚠ **¡ADVERTENCIA!** No recomendado para niños menores de 3 años. Piezas pequeñas. Existe riesgo de atragantamiento. Lave perfectamente los accesorios antes de su uso. El montaje del producto deberá efectuarlo un adulto. Retire todos los elementos del embalaje antes de permitir que el niño utilice el juguete. Conserve la dirección para futuras consultas. Lave perfectamente los accesorios antes de su uso.

I ⚠ **AVVERTENZA !** Non adatto ai bambini di età inferiore ai 3 anni. Piccole parti. Pericolo di asfissia. Lavare accuratamente gli accessori prima dell'uso. Montaggio dell'articolo a cura di un adulto. Eliminare gli imballi prima di dare il giocattolo al bambino. Conservare per future referenze. Lavare accuratamente gli accessori prima dell'uso